

EXPULSOR DE MUELLE EMA SPRING PLUNGER EMA

Material:

Cuerpo: Acero de decoletaje, pavonado / Body: Blued steel for casting

Vástago: Acero de decoletaje, templado / Rod: Tempered steel for casting

STOCK

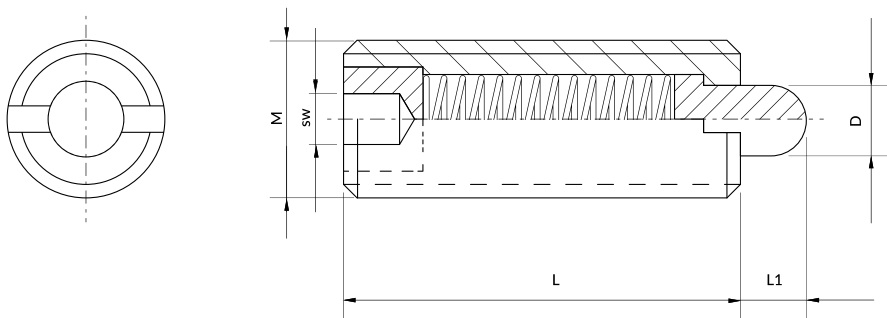

M	L	L1	D	sw	Spring Pressure daN		Duty
					Min.	Max.	
M3	10	1,5	1	0,8	0,05	0,3	HEAVY (H)
M4	12	2	1,6	0,8	0,2	1	
M5	20	3	2	1,5	0,4	2	
M6	25	3	2,5	2	0,8	3	
M8	25	3	3,1	2,5	0,8	3	
M10	30	5	3,8	3	1	5	
M12	30	5	5,5	4	1	5	LIGHT (L)
M5	20	3	2	1,5	0,2	1	
M6	25	3	2,5	2	0,3	1	
M8	25	3	3,1	2,5	0,3	1	
M10	30	5	3,8	3	0,3	1,5	
M12	30	5	5,5	4	0,2	1	

How to order: EMA + M + L1 + Duty