

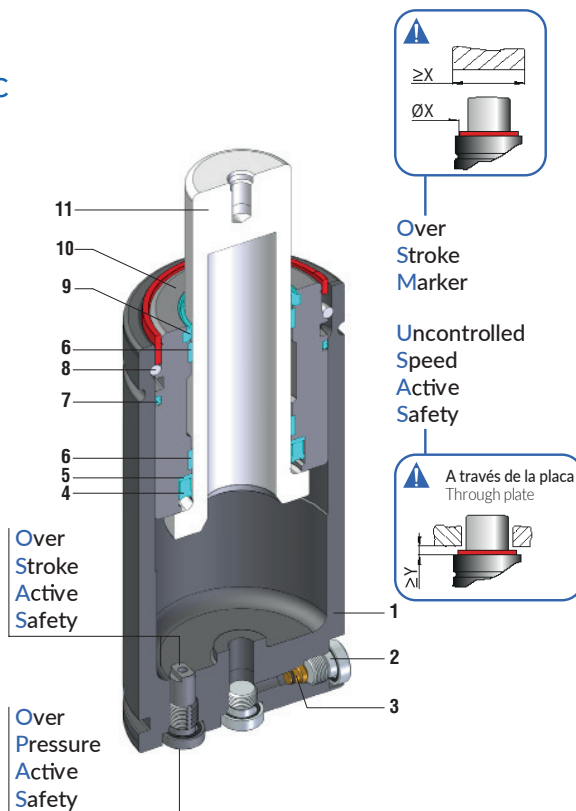





## CILINDRO SC GAS SPRING SC

STOCK



Standard: ISO, VDI

Model	Body Ø	Stroke Cu	Initial force F0	 OSAS	 USAS	 OPAS	 SKUDO	 SW (optional)
	mm	mm	daN					
SC 150	32	10 125	170	•	•	•	-	•
SC 250	38	10 125	260	•	•	•	-	•
SCF 250	M38 X 1,5	10 125	260	•	•	•	-	•
SC 500	45	10 125	470	•	•	•	-	•
SC 750	50	13 125	740	•	•	•	-	•
SC 1500	75	13 125	1530	•	•	•	-	•
SC 3000	95	13 125	2945	•	•	•	-	•
SC 5000	120	25 125	4980	•	•	•	-	•
SC 7500	150	25 125	7540	•	•	•	-	•
SC10000	195	25 125	10600	•	•	•	-	•

1	Cuerpo / Body
2	Válvula / Valve
3	Tapón / Plug
4	Retén / Rod seal
5	Anillo antiextrusión / Back-up ring
6	Anillo guía / Guide ring
7	Anillo dual / Dual ring seal
8	Anillo de retención / Retaining ring
9	Rascador / Rod wiper
10	Casquillo / Bush
11	Vástago (niturado) / Rod (nitrited super finished)

CILINDRO SC  
GAS SPRING SC

Available versions

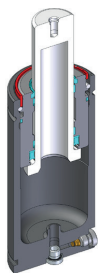

Standard code



GAS SPRING

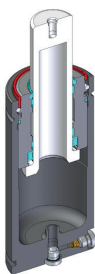

Standard code + W



GAS SPRING  
+  
Secondary wiper



See p. Ct163

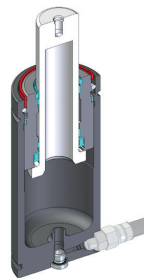

Standard code + N



Linkable  
See p. Ct157

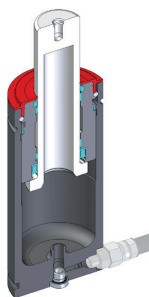

Standard code + N-W



Linkable  
+  
Secondary wiper



See p. Ct157

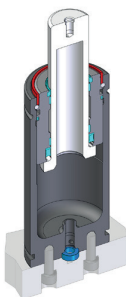

Standard code + E



Easy Manifold



See p. Ct158

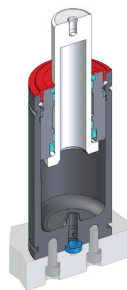

Standard code + E-W



Easy Manifold  
+  
Secondary wiper



See p. Ct158 + Ct163

# CILINDRO SC 250 GAS SPRING SC 250



SW

Active safety



OSAS



USAS



OPAS

\* F<sub>1i</sub> =  
Isothermal end  
force at 100% Cu

\* F<sub>1p</sub> =  
Polytropic end  
force at 100% Cu

**OSAS + OSM** = OVER STROKE + OVER STROKE ACTIVE MARKER SAFTY

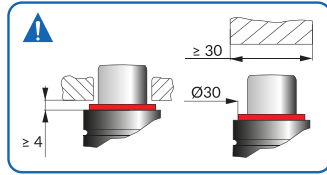

Assembly recommendation

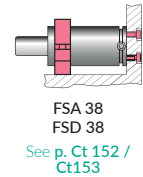
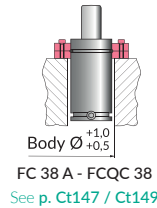
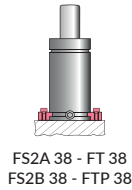
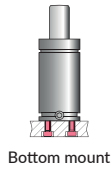
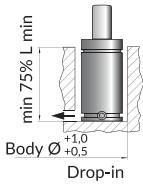
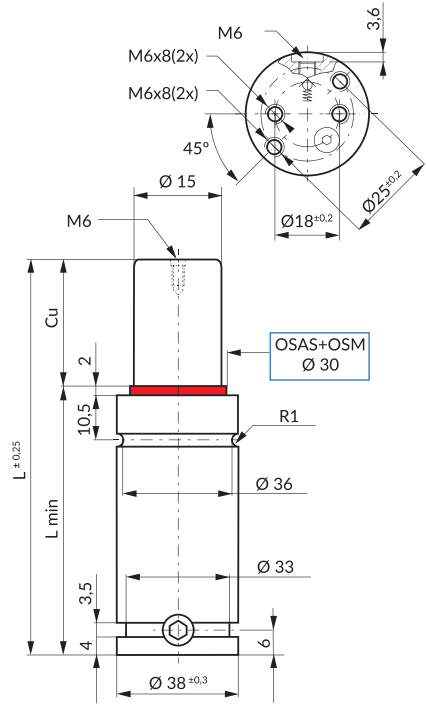

Standard: ISO 11901-1, VDI 3003

		ΔP ± 0,33 % / °C	P max 150 bar	P min 20 bar	S 1,77 cm <sup>2</sup>	SPM ~80 - 100 (at 20°)	Max Speed 1.8 m/s	Maintenance kit 39BMS00250E
--	--	---------------------	------------------	-----------------	---------------------------	------------------------------	----------------------	--------------------------------

Code	Cu	L	L min	F0 Initial force	F <sub>1i</sub> End force*	F <sub>1p</sub> End force*	V0		PED 2014/68/EU
	mm	mm	mm	daN	daN	daN	cm3		
SC 250 010	10	70	60	260 ± 5% 150bar +20°C	305	334	16	0,40	•
SC 250 013	12,7	75,4	62,7		310	342	18,1	0,41	•
SC 250 016	16	82	66		316	350	20,6	0,43	•
SC 250 016	19	88	69		320	357	22,9	0,45	•
SC 250 025	25	100	75		327	366	27,4	0,48	•
SC 250 038	38	126	88		336	380	37,3	0,54	•
SC 250 050	50	150	100		341	387	46,5	0,60	•
SC 250 063	63,5	177	113,5		345	393	56,7	0,66	•
SC 250 080	80	210	130		348	398	69,3	0,74	•
SC 250 100	100	250	150		351	403	84,2	0,81	•
SC 250 125	125	300	175		355	409	101,6	0,98	•

How to order: Code