

CÁNCAMO ELEVACIÓN MACHO CEM LIFTING BRACKET CEM

STOCK

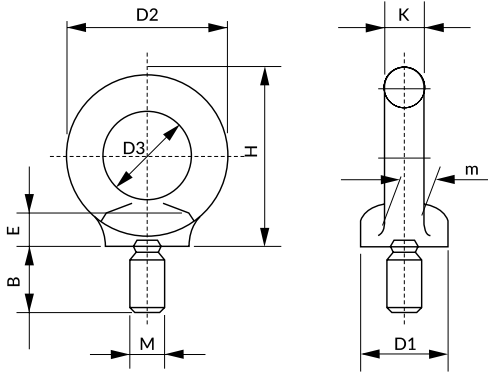

CE 2006/42/CE
Standard: DIN 580

M	B min	D1	D2	D3	E	H	K	m	Weight kg	Capacity t	
										1 piece 0°	2 pieces 0-45°
M6	11	20	36	15	6	36	8	10	0,03	0,08	0,055
M8	13	20	36	20	6	36	8	10	0,06	0,14	0,095
M10	17	25	45	25	8	45	10	12	0,11	0,23	0,17
M12	20,5	30	54	30	10	53	12	14	0,18	0,34	0,24
M16	27	35	63	35	12	62	14	16	0,28	0,7	0,5
M20	30	40	72	40	14	71	16	19	0,45	1,2	0,83
M22	33	50	90	42	18	90	20	24	0,72	1,4	1,05
M24	36	50	90	50	18	90	20	24	0,74	1,8	1,27
M30	45	65	108	60	22	109	24	28	1,66	3,6	2,6
M36	54	75	126	70	26	128	28	32	2,65	5,1	3,7
M42	63	85	144	80	30	147	32	38	4,03	7	5
M48	68	100	166	90	35	168	38	46	6,38	8,6	6,1
M56	78	110	184	100	38	187	42	50	8,8	11,5	8,3
M64	90	120	206	110	42	208	48	58	12,4	16	11
M72	100	150	260	140	50	260	60	72	23,3	21	15
M80	112	170	296	160	55	298	68	80	34,2	28	20

How to order: CEM + M